

AIR CYLINDER

Series A51, A52

Cat No A51 - 03

AIR CYLINDERS Double Acting (Ø12 - 25) mm

As per ISO 6432 / CETOP RP52P standards

Features

- Elastomer cushioning at both ends.
- Wide varieties of mountings.
- Low friction.
- Long life.



Technical Specifications

Cylinder bore Ø (mm)	12	16	20	25
Standard strokes * (mm)	10 25 40 50 80 100 125 160 200 250 300			
Medium	Compressed air - filtered - lubricated			
Working pressure	0.5 - 10 bar			
Medium temperature	5° - 60° C			
Materials of construction	Aluminium, Brass, Nitrile, Polyurethane, Steel, Acetal			
Mountings	Front foot mounting, Double foot mounting, Front flange, Rear flange, Front trunnion, Rear trunnion			
Accessories	Clevis foot bracket, Trunnion bracket, Rod end fork, Rod end aligner			

* For Non standard or longer stroke cylinders, contact your regional dealer or JANATICS

Output force (force in N : 1N = 0.1 kgf)

Cylinder bore Ø (in mm)	Rod Ø (in mm)		Working pressure in bar								
			2	3	4	5	6	7	8	9	10
12	6	Extend	20	30	40	50	60	70	80	90	100
		Retract	15	22	30	38	46	53	61	68	76
16	6	Extend	36	54	72	90	108	126	144	162	180
		Retract	31	46	62	78	94	108	124	140	156
20	8	Extend	56	84	112	140	169	196	224	254	282
		Retract	47	71	95	118	142	166	189	214	237
25	10	Extend	88	132	176	220	264	308	352	396	440
		Retract	74	111	148	185	222	260	296	334	371

(Above values have been worked out taking frictional loss into consideration)

AIR CYLINDER

Series A51, A52

Cat No A51 - 03

Basic cylinder

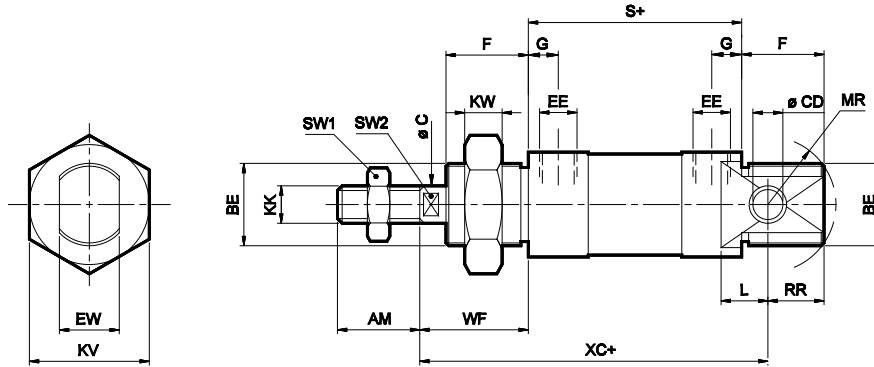

+ Add stroke

Cylinder bore Ø	MR	BE	F	CD H9	RR	L	G	EE	S	KW	C	SW1	SW2	KK	AM	WF ±1.2	XC ±1	EW d13	KV	Stroke tol	
																				10 - 100	Above 100
12	17	M16x1.5	17	6	15	9	6	M5x0.8	51 ^{+0.5}	8	6	10	5	M6x1	16	22	75	12	24	+ 1.5 + 0	+ 2.5 + 0
16	17	M16x1.5	17	6	15	9	6	M5x0.8	58 ^{+0.5}	8	6	10	5	M6x1	16	22	82	12	24		
20	20	M22x1.5	20	8	16	12	8	G1/8	67 ^{+0.7}	10	8	13	7	M8x1.25	20	24	95	16	32		
25	21	M22x1.5	22	8	17	12	8	G1/8	71 ^{+0.7}	10	10	17	9	M10x1.25	22	28	104	16	32		

MOUNTINGS FOR AIR CYLINDER Series A51

Front Foot Mounting

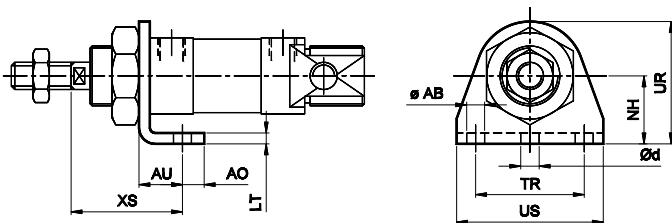

Cylinder bore Ø	LT	AU	AO	d*	XS ±1.4	NH ±0.3	TR Js14	US	AB H13	UR	Ordering no.
12	2	12	6	4.8	32	20	32	42	5.5	33	ML016
16	2	12	6	4.8	32	20	32	42	5.5	33	ML016
20	4	16	8	5.8	36	25	40	54	6.6	45	ML022
25	4	16	8	5.8	40	25	40	54	6.6	45	ML022

* Suitable for reaming

Double Foot Mounting

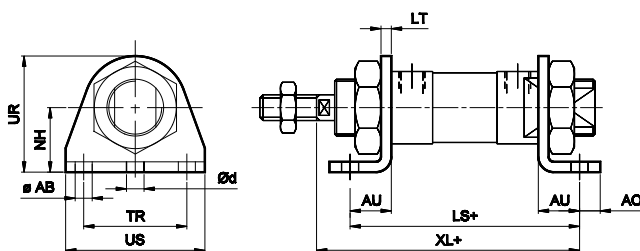

+ Add stroke

Cylinder bore Ø	UR	AB H13	TR Js14	NH ±0.3	AO	AU	d*	LT	US	LS	XL ±1	Ordering no.
12	33	5.5	32	20	6	12	4.8	2	42	75 ^{+0.7}	85	MS016
16	33	5.5	32	20	6	12	4.8	2	42	82 ^{+0.7}	92	MS016
20	45	6.6	40	25	8	16	5.8	4	54	99 ^{+0.9}	107	MS022
25	45	6.6	40	25	8	16	5.8	4	54	103 ^{+0.9}	115	MS022

* Suitable for reaming

AIR CYLINDER

Series A51, A52

Cat No A51 - 03

Front flange

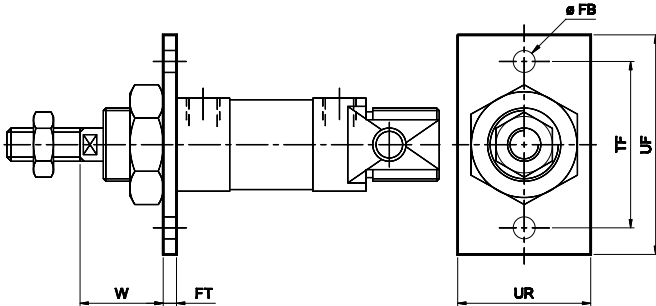

Cylinder bore Ø	TF Js14	UF	UR	FB H13	FT	W ±1.4	Ordering no.
12	40	50	30	5.5	4	18	MF016
16	40	50	30	5.5	4	18	MF016
20	50	66	40	6.6	5	19	MF022
25	50	66	40	6.6	5	23	MF022

Rear flange

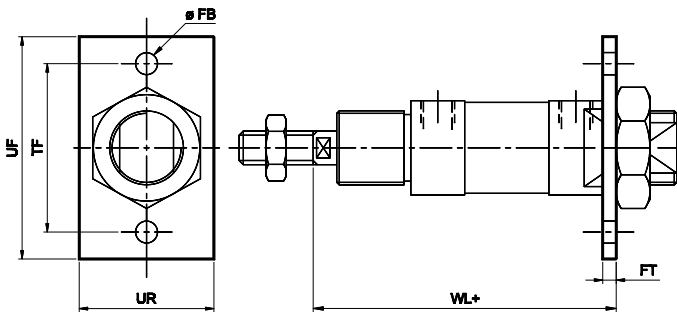

+ Add stroke

Cylinder bore Ø	TF Js14	UF	UR	FB H13	FT	WL ±1.2	Ordering no.
12	40	50	30	5.5	4	77	MF016
16	40	50	30	5.5	4	84	MF016
20	50	66	40	6.6	5	96	MF022
25	50	66	40	6.6	5	104	MF022

Front trunnion

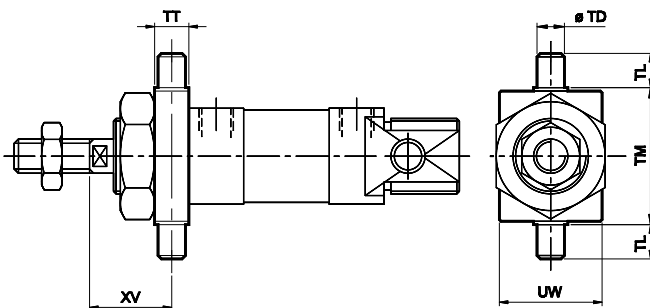

Cylinder bore Ø	TM h14	UW	TD e9	TT	XV ±1.4	TL h14	Ordering no.
12	30	25	6	8	18	10	MT016
16	30	25	6	8	18	10	MT016
20	40	30	8	10	19	10	MT022
25	40	30	8	10	23	10	MT022

Rear trunnion

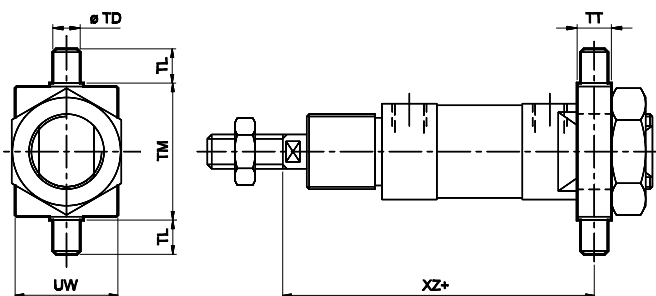

+ Add stroke

Cylinder bore Ø	TM h14	UW	TD e9	TT	XZ ±1.2	TL h14	Ordering no.
12	30	25	6	8	77	10	MT016
16	30	25	6	8	84	10	MT016
20	40	30	8	10	96	10	MT022
25	40	30	8	10	104	10	MT022

For trunnion brackets see "Accessories "

AIR CYLINDER

Series A51, A52

Cat No A51 - 03

Accessories for Air Cylinder series A51, A52

Clevis foot bracket (CETOP - RP 107 P)

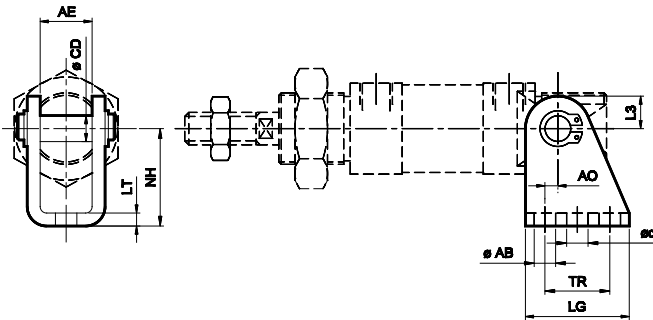

Cylinder bore \varnothing	AE	AB H13	LT	NH	L3	CD e8	d*	TR Js14	LG	AO	Ordering no.
12	12.1	5.5	2	27	7	6	3.8	15	25	2	AA016
16	12.1	5.5	2	27	7	6	3.8	15	25	2	AA016
20	16.1	6.6	4	30	10	8	4.8	20	32	4	AA022
25	16.1	6.6	4	30	10	8	4.8	20	32	4	AA022

* Suitable for reaming

Trunnion bracket

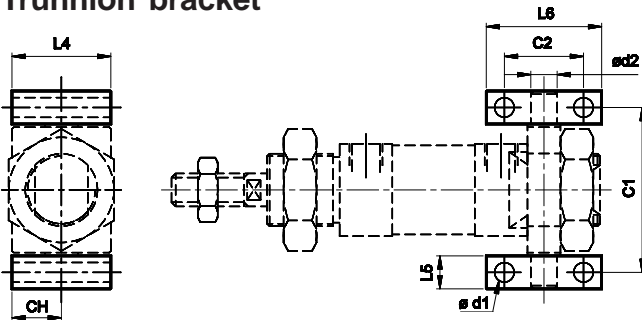

Cylinder bore \varnothing	C1	C2 Js14	d1 H13	L4	L5	L6	CH	d2 H9	Ordering no.
12	38	20	4.3	25	8	30	16	6	AT016
16	38	20	4.3	25	8	30	16	6	AT016
20	50	24	6.6	30	10	35	20	8	AT022
25	50	24	6.6	30	10	35	20	8	AT022

Rod end Fork (ISO 8140)

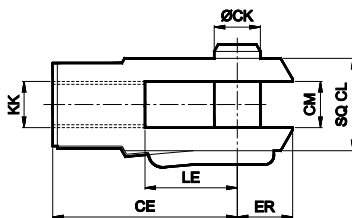

Cylinder bore \varnothing	KK	LE	CM B12	CE	CK f8	CL	ER	Ordering no.
12	M6X1	12	6	24	6	12	9.5	AF006
16	M6X1	12	6	24	6	12	9.5	AF006
20	M8X1.25	16	8	32	8	16	13	AF008
25	M10X1.25	20	10	40	10	20	16	AF010

Rod end Aligner

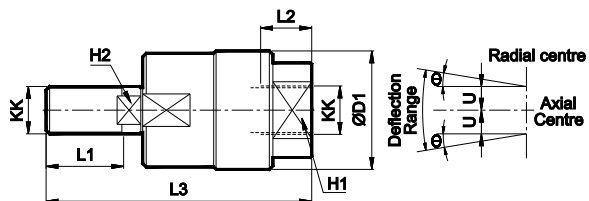

Cylinder bore \varnothing	KK	L1	L2	L3	D1	H1	H2	$\pm \theta^\circ$	U	Ordering no.
12 / 16	M6X1	12	8	38	18	10	4	5	0.75	AR006
20	M8X1.25	15	10	48	20	12	7	5	0.75	AR008
25	M10X1.25	20	14	65	28	17	8	5	0.75	AR010

Rod end spherical eye

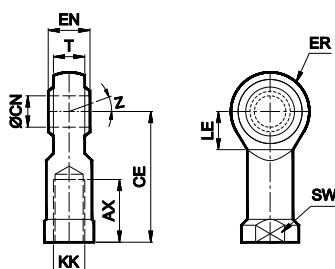

Cylinder bore \varnothing	KK	CN H9	T	EN h12	CE	LE min	ER max	AX	SW h13	Z	Ordering no.
12 / 16	M6X1	6	6.75	9	30	11	10	12	11	13°	AP006
20	M8X1.25	8	9	12	36	13	12	16	13 / 14		AP008
25	M10X1.25	10	10.5	14	43	15	14	20	17		AP010

AIR CYLINDER

Series A51, A52

Cat No A51 - 03

ACCESSORIES FOR MAGNETIC CYLINDERS Series A52, A55

REED SWITCH

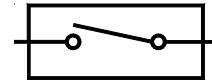

Function

The reed switch and clamping kit assembly is mounted on the Air cylinder (Series A52, A55), for proximity sensing. The piston of the cylinder is equipped with a permanent magnet which activates the reed switch on approaching it. The reed switch closes the circuit giving an electrical signal, which could be used further as required. The accuracy of the sensing distance depends on the speed of operation of the piston.

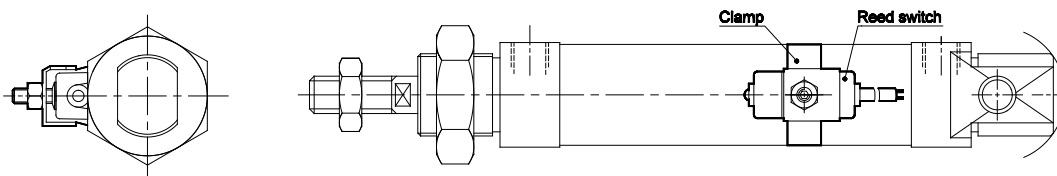

Technical Specifications - Reed Switch

Model	880006
Operating voltage	DC / AC 5 - 240V
Switching current	100mA max
Switch rating	10 W max
Voltage drop	3.5V max.
Response time	On + off <1ms
Switching logic	SPST, Normally open
Operating temperature	-10° to +70° C
Shock	30 G
Vibration	9 G
Protection circuit	None
Type of protection	IEC 529, IP67
Colour of LED	Green
Cable	Ø4, 2C, 2meter

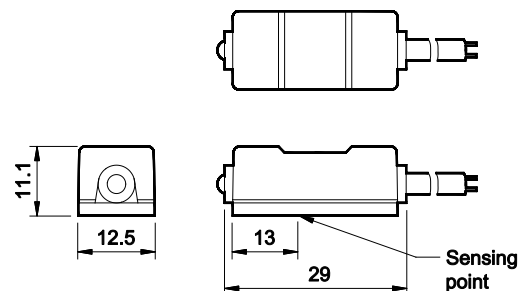

Bore Dia	X	Ordering no. for Clamp (a)	Ordering no. for Reed Switch (b)	Ordering no. (a+b)
12	32	810000	880006	AM1012
16	34	810001		AM1016
20	36	810002		AM1020
25	38	810003		AM1025

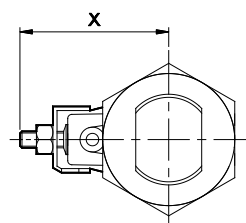

Circuit and connect diagram

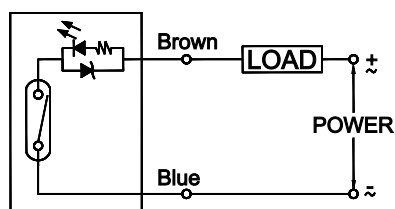

AIR CYLINDER

Series A51, A52

Cat No A51 - 03

How to order

Model		Bore Ø (mm)		Stroke (mm)		Mountings	
51	Standard cylinder	012	- Ø 12	010	- 10	O	- Basic
52	Magnetic cylinder	016	- Ø 16	025	- 25	L	- Front Foot Mounting
		020	- Ø 20	040	- 40	D	- Double Foot Mounting
		025	- Ø 25	050	- 50	F	- Front Flange
				080	- 80	R	- Rear Flange
				100	- 100	M	- Front Trunnion
				125	- 125	N	- Rear Trunnion
				160	- 160		
				200	- 200		
				250	- 250		
				300	- 300		

Example:

Ordering no. for standard cylinder with 16 dia bore, 50 mm stroke with Double foot mounting : **A51 016 050 D**



Note:

If ordered as 16 dia, 50 mm stroke cylinder, Basic cylinder **A51 016 050 O** will be supplied.

For repeat order when the details are taken from cylinder nameplate, mention the mounting style separately.

For ordering **Accessories**: mention part numbers in corresponding tables.

For ordering individual **Mounting** kits (If needed separately): mention the ordering numbers as below

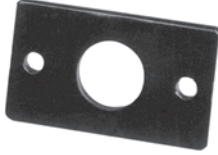
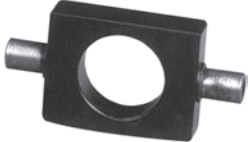
Cylinder bore Ø	Front Foot mounting	Double Foot mounting	Flange (Front or Rear)	Trunnion (Front or Rear)
				
12	ML016	MS016	MF016	MT016
16	ML016	MS016	MF016	MT016
20	ML022	MS022	MF022	MT022
25	ML022	MS022	MF022	MT022

For your special requirements of cylinders or for further informations contact your regional dealer or **JANATICS**